

ZONE	REV	DESCRIPTION	REVISIONS	DATE	APPROVED

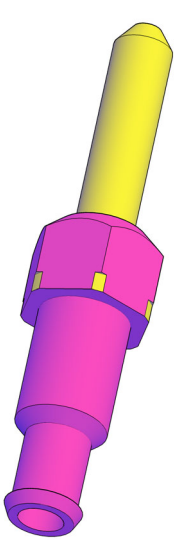

PART 1

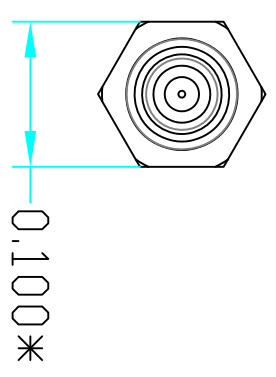
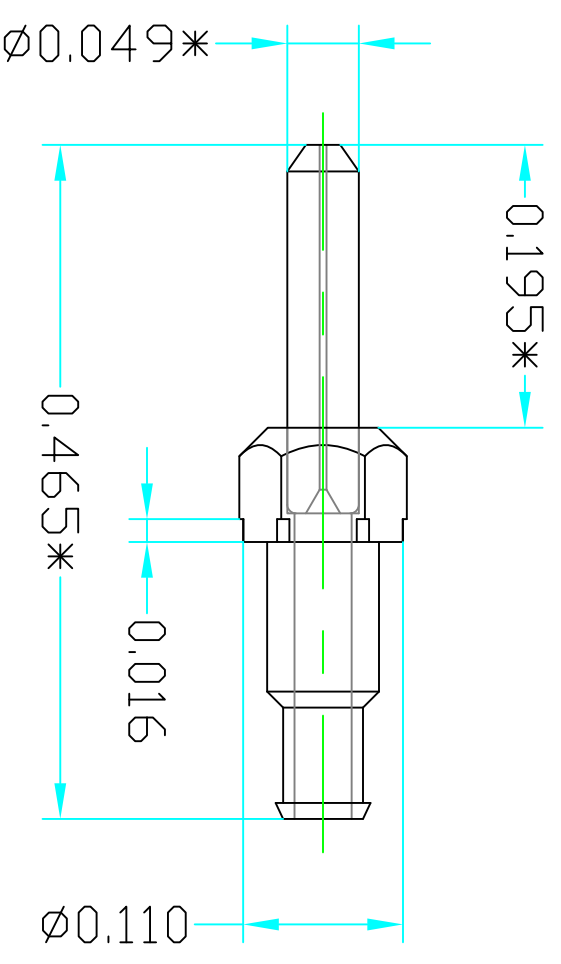
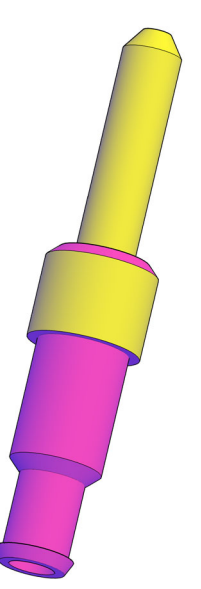
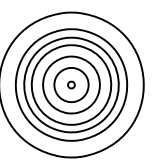
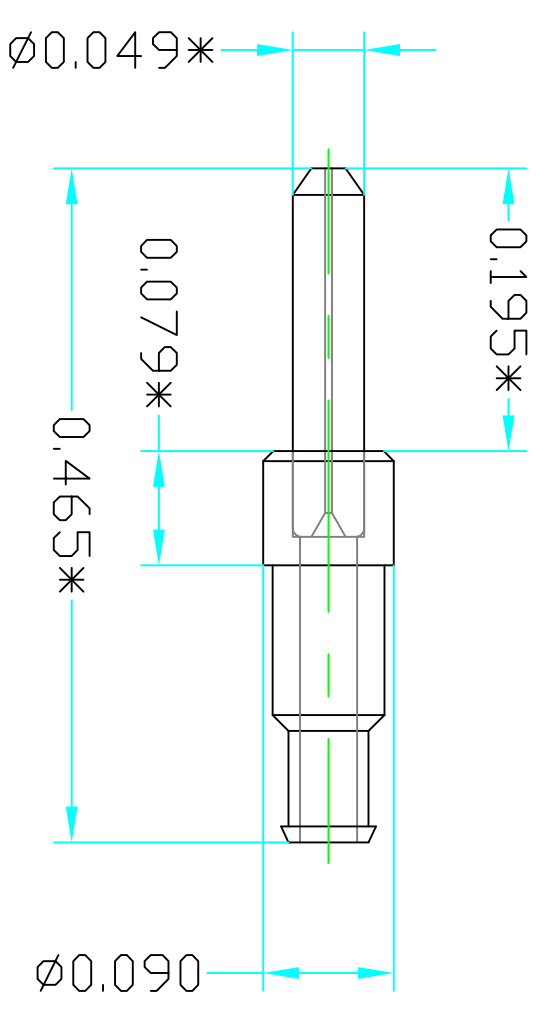

PART 2

A  
B  
C  
D

6  
5  
4  
3  
2  
1

UNLESS OTHERWISE SPECIFIED		FERRULES VARIATION IN INCH DIMENSIONS WITHOUT TOLERANCES		MACHINING TOLERANCES	
12 TO 60	±0.10	BEHIND	±0.005	±0.005	±0.002
60 TO 180	±0.20	BEHIND	±0.010	±0.010	±0.004
OVER 180	±0.30	OVER	±0.020	±0.015	±0.010

PARTS LIST		SURFACE TEXTURE	
PART 2	30 EA FERRULE	ZIRCONIA	PPF INC. MM-FER2007CF-XXXX
PART 1	30 EA FERRULE	ZIRCONIA	PPF INC. MM-FER2007CF-XXXX

1. DIMENSIONS ARE IN INCHES.	2. MACHINING SURFACES TO BE FLAT, SQUARE, PARALLEL & CONCENTRIC BELLY 12	3. MARK ALL DETAILS EXCEPT COMMERCIAL PARTS WITH DWG.	4. BREAK ALL SHARP CORNERS .01 x 45° CHAMFER.	5. FILET'S SHOWN SHARP = .04 RAD.	6. TYPICAL BREAKS, BEHIND TOLERANCES 1/16 x 45°.	7. CENTER PERMISSIBLE.	8. DO NOT SCALE DRAWING.	9. DO NOT SCALE DRAWING.	10. ALL WELDING TO CONFORM TO LATEST AWS STANDARDS.
------------------------------	--	---	---	-----------------------------------	--	------------------------	--------------------------	--------------------------	---

NAME	DATE	DATE
AD	05/06/22	
KH		

REV	DATE	BY	CHKD	APP'D	TITLE
1	DF	1			DFPS SETUP 4X4 FERRULE

SIZE	SCALE	DRAWING NUMBER	REVISION
D		227	A

Open Source Instruments Inc.



REV	DATE	BY	CHKD	APP'D	TITLE
1	DF	1			DFPS SETUP 4X4 FERRULE

REV	DATE	BY	CHKD	APP'D	TITLE
1	DF	1			DFPS SETUP 4X4 FERRULE

REV	DATE	BY	CHKD	APP'D	TITLE
1	DF	1			DFPS SETUP 4X4 FERRULE